



N-Channel Enhancement Mode Field Effect Transistor

Product Summary

- V_{DS} 60 V
- I_D 50 A
- $R_{DS(ON)}$ (at $V_{GS}=10V$) <15 mohm
- $R_{DS(ON)}$ (at $V_{GS}=4.5V$) <17 mohm
- 100% EAS Tested



YJD50N06A

■ Electrical Characteristics (T_J=25°C unless otherwise noted)

Parameter	Symbol	Conditions	Min	Typ	Max	Units
Static Parameter						
Drain-Source Breakdown Voltage	BV _{DSS}	V _{GS} = 0V, I _D =250μA	60			V
Zero Gate Voltage Drain Current	I _{DSS}	V _{DS} =60V, V _{GS} =0V			1	μA
Gate-Body Leakage Current	I _{GSS}	V _{GS} = ±20V, V _{DS} =0V			±100	nA
Gate Threshold Voltage	V _{GS(th)}	V _{DS} = V _{GS} , I _D =250μA	1.0	1.5	2.5	V
Static Drain-Source On-Resistance	R _{DS(on)}	V _{GS} = 10V, I _D =15A		11	15	mΩ
		V _{GS} = 4.5V, I _D =10A		13.5	17	
Diode Forward Voltage	V _{SD}	I _S =15A, V _{GS} =0V		0.80	1.2	V
Maximum Body-Diode Continuous Current	I _S				50	A
Gate resistance	R _g	f=1 MHz, Open drain		2.1		Ω
Dynamic Parameters						
Input Capacitance	C _{iss}	V _{DS} =30V, V _{GS} =0V, f=1MHZ		2585		pF
Output Capacitance	C _{oss}			150		
Reverse Transfer Capacitance	C _{rss}			77.5		
Switching Parameters						
Total Gate Charge	Q _g (10V)	V _{GS} =10V, V _{DS} =30V, I _D =20A		51		nC
Total Gate Charge	Q _g (4.5V)			24		
Gate-Source Charge	Q _{gs}			9.5		
Gate-Drain Charge	Q _{gd}			10		
Reverse Recovery Charge	Q _{rr}	I _r =20A, di/dt=100A/us		17		
Reverse Recovery Time	t _{rr}			14		
Turn-on Delay Time	t _{D(on)}	V _{GS} =10V, V _{DD} =30V, I _D =20A R _{GEN} =3Ω		11		ns
Turn-on Rise Time	t _r			25		
Turn-off Delay Time	t _{D(off)}			89		
Turn-off fall Time	t _f			79		

A. Pulse Test: Pulse Width ≤ 300us, Duty cycle ≤ 2%.

B. The power dissipation P_D is based on T_{J(MAX)}=150°C, using junction-to-case thermal resistance, and is more useful in setting the upper dissipation limit for cases where additional heatsinking is used.

C. The value of R_{θJA} is measured with the device mounted on 1in2 FR-4 board with 2oz. Copper, in a still air environment with T_A=25°C.

D. T_J=25°C, V_{DD}=55V, V_G=10V, L=0.5mH.



Typical Performance Characteristics

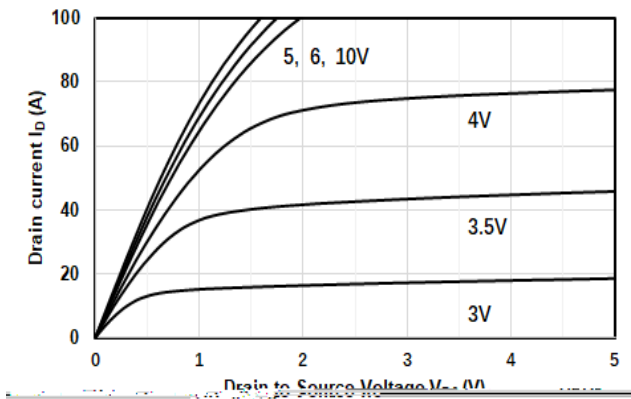

Figure1. Output Characteristics

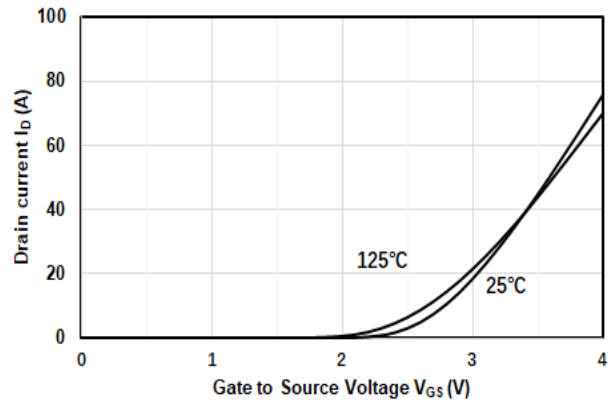

Figure2. Transfer Characteristics

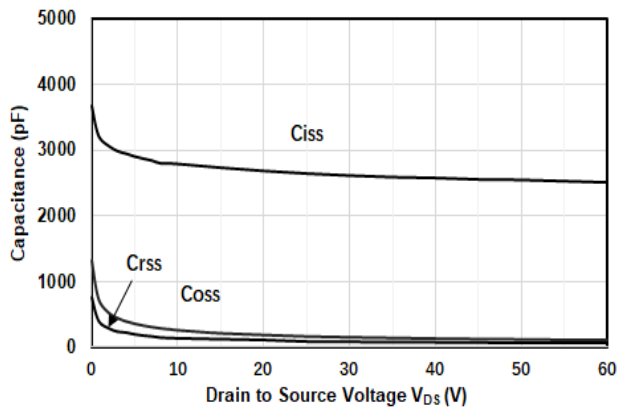

Figure3. Capacitance Characteristics

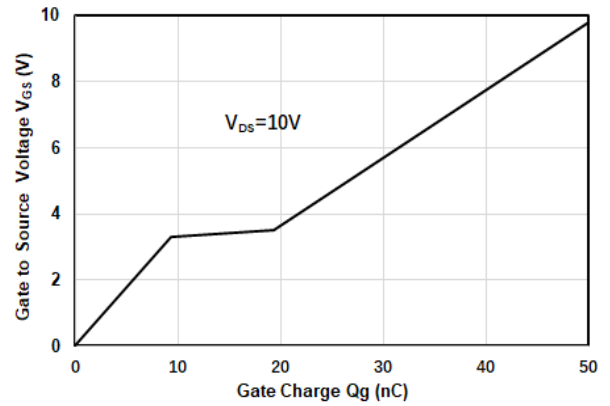

Figure4. Gate Charge

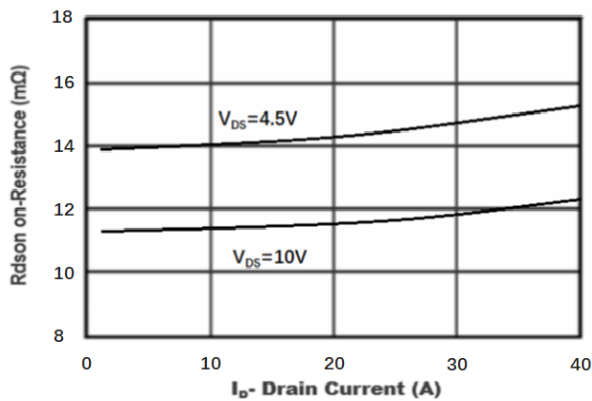

Figure5. Drain-Source on Resistance

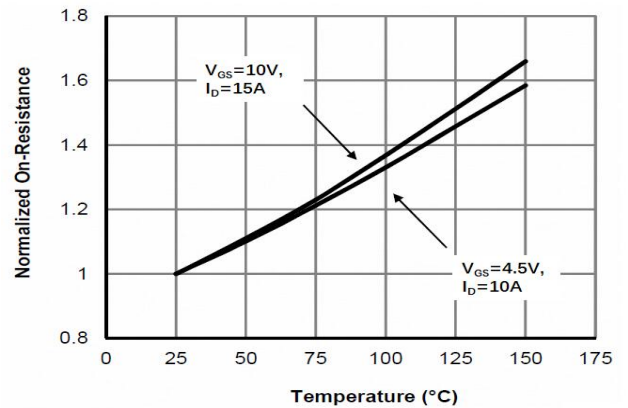

Figure6. Drain-Source on Resistance



YJD50N06A

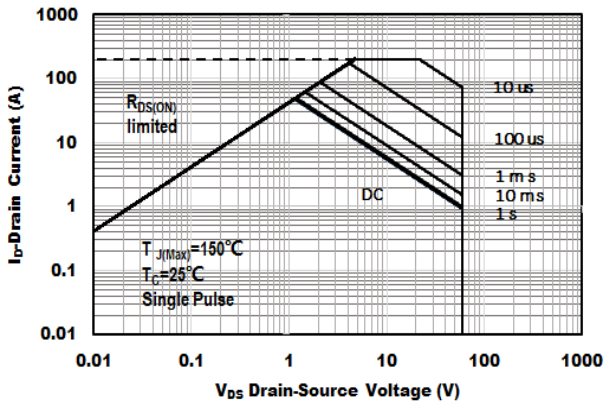

Figure7. Safe Operation Area

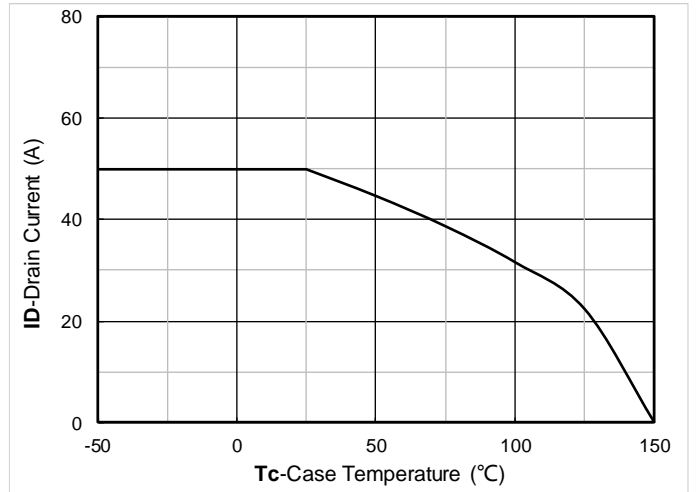

Figure8. Drain current vs. Case Temperature

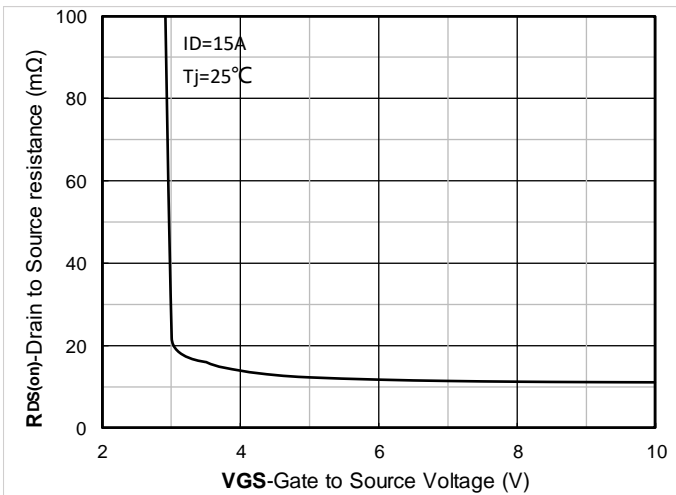

Figure 9. On-Resistance vs Gate to Source Voltage

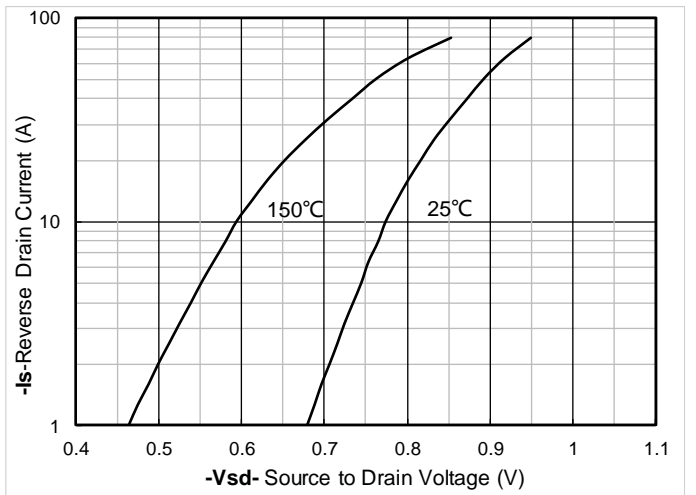

Figure 10. Forward characteristics of reverse diode

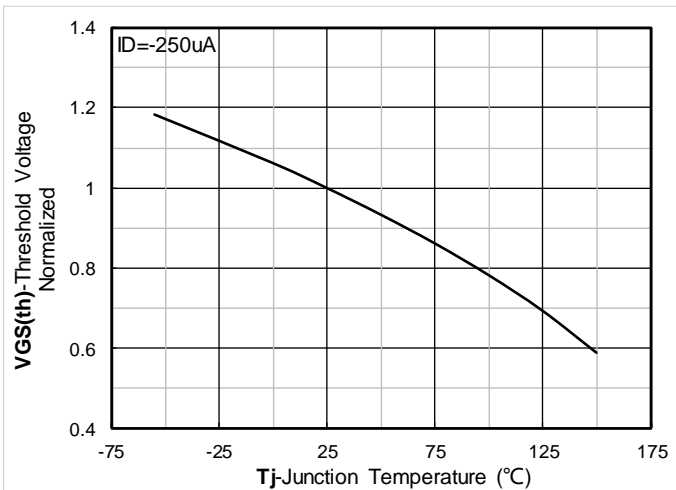

Figure 11. Normalized Threshold voltage

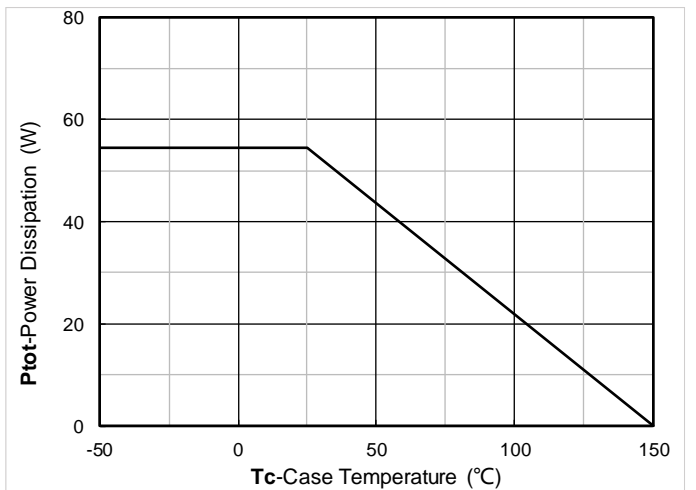

Figure 12. Power dissipation



YJD50N06A

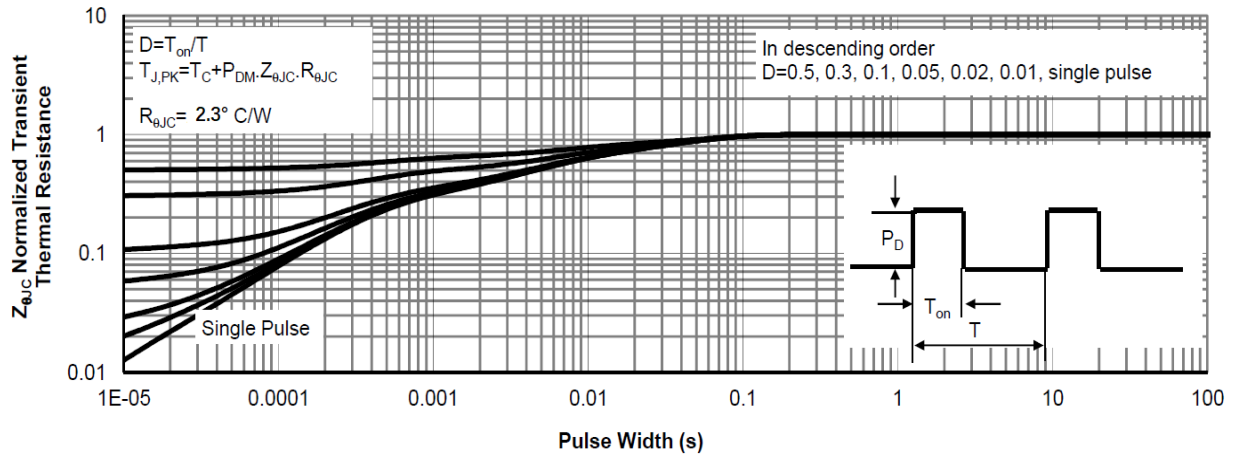
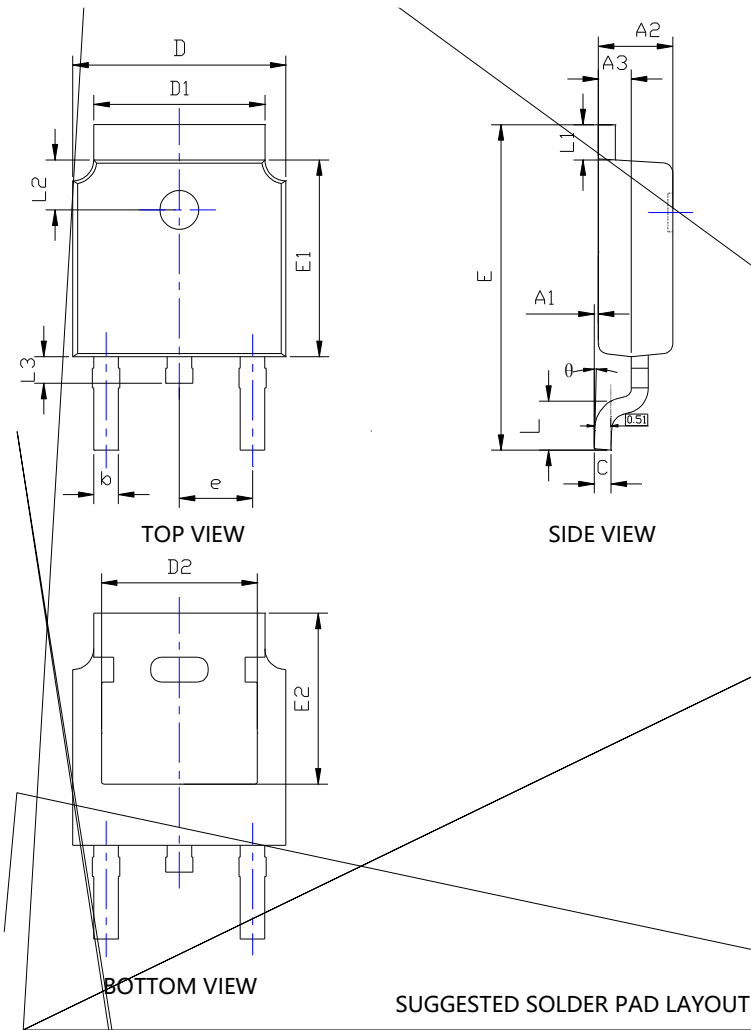

Figure13. Normalized Maximum Transient Thermal Impedance



YJD50N06A

TO-252-B Package information



SYMBOL	DIMENSIONS					
	INCHES			Millimeter		
	MIN.	NOM.	MAX.	MIN.	NOM.	MAX.
A1	0.000	---	0.008	0.000	---	0.200
A2	0.087	0.091	0.094	2.200	2.300	2.400
A3	0.035	0.039	0.043	0.900	1.000	1.100
b	0.026	0.030	0.034	0.660	0.760	0.860
c	0.018	0.020	0.023	0.460	0.520	0.580
D	0.256	0.260	0.264	6.500	6.600	6.700
D1	0.203	0.209	0.215	5.150	5.300	5.450
D2	0.181	0.189	0.195	4.600	4.800	4.950
E	0.390	0.398	0.406	9.900	10.100	10.300
E1	0.236	0.240	0.244	6.000	6.100	6.200
E2	0.203	0.209	0.215	5.150	5.300	5.450
e	0.090BSC			2.286BSC		
L	0.049	0.059	0.069	1.250	1.500	1.750
L1	0.03					
L2	0.055		0.075	1.400		1.900
L3	0.240	0.310	0.039	0.600		1.000
L4	0.114REF					
θ	0°		10°	0°		10°

NOTE:
 1. PACKAGE BODY SIZES EXCLUDE MOLD FLASH AND GATE BURRS.
 2. TOLERANCE 0.1mm UNLESS OTHERWISE SPECIFIED.
 3. THE PAD LAYOUT IS FOR REFERENCE PURPOSES ONLY.



YJD50N06A

Disclaimer

The information presented in this document is for reference only. Yangzhou Yangjie Electronic Technology Co., Ltd. reserves the right to make changes without notice for the specification of the products displayed herein to improve reliability, function or design or otherwise.

The product listed herein is designed to be used with ordinary electronic equipment or devices, and not designed to be used with equipment or devices which require high level of reliability and the malfunction of which would directly endanger human life (such as medical instruments, transportation equipment, aerospace machinery, nuclear-reactor controllers, fuel controllers and other safety devices), Yangjie or anyone on its behalf, assumes no responsibility or liability for any damages resulting from such improper use of sale.

This publication supersedes & replaces all information previously supplied. For additional information, please visit our website [http:// www.21yangjie.com](http://www.21yangjie.com) , or consult your nearest Yangjie's sales office for further assistance.